

## AC6275

2-3/4 inch through-bore

### Description

A slip ring can be used in any electromechanical system that requires unrestrained, continuous rotation while transferring power and / or data from a stationary to a rotating structure. A slip ring is also called a rotary electrical interface, collector, swivel or a commutator. A slip ring can improve system performance by simplifying operations and eliminating damage-prone wires dangling from movable joints.

The 2-3/4 inch unobstructed through-bore provides routing space for hydraulics, pneumatics or for a concentric shaft mount.

The AC6275 uses our fiber brush technology which offers several advantages over conventional slip ring contacts including multiple points of contact per brush bundle, low contact force per fiber and low contact wear rates. In addition, fiber brushes do not require lubrication and produce virtually no wear debris. The AC6275 features field serviceable brush blocks.

### Features

- 2-3/4 inch through-bore
- Compact 6.63 inch outside diameter
- Modular design - a single module can have: one 50 amp ring; two 30 amp rings; one, two or three 10 amp rings or six 5 amp signal rings
- Up to 24-50 amp circuits, 48-30 amp circuits, 72-10 amp rings or 144-5 amp rings in a 24 module length, or combinations of all four in a single housing
- Speeds up to 1,000 rpm continuous
- Steel bearings and machined shaft and housing for harsh environments
- Collar mounting is standard; flange mounting is optional
- Various lead exits are available
- Silver plated rings are standard. Gold plated, optional.
- 20, 16, 10 and 8 gauge lead wire
- Continuous 360° rotation of power or data signals
- Sealed unit
- Available as slip ring / brush block separates
- Brush assemblies are field serviceable

### Benefits

- Transfers control and data signals
- Fiber brush technology provides maintenance-free operation (no lubrication required)
- Modular design meets special requirements through off-the-shelf manufacturing techniques
- Customized configurations for your application



### Typical Applications

- Industrial machinery – machining centers, rotary index tables, heavy equipment turrets or cable reels, test equipment, packaging and palletizing machines, magnetic clutches, process equipment, rotary sensors, emergency lighting, robotics
- Exhibit / display equipment
- Medical equipment

# Slip Rings With Through-Bores

AC6275 Specifications		Options
Operating Speed	1,000 rpm* continuous	<ul style="list-style-type: none"> <li>• Longer lead lengths available</li> <li>• Power and signal combinations</li> <li>• Rotor and stator lead exits</li> <li>• Gold plated rings</li> <li>• Seamed housing standard, solid housing optional</li> <li>• IP65 sealing (P/N AC6793), see page 33</li> </ul>
Number of Circuits	Various configurations	
Lead Lengths	12 inch (304 mm) min. from point of exit	
Lead Size	Signal circuits: #20 AWG, 5 amps #16 AWG, 10 amps Power circuits: #10 AWG, 30 amps #8 AWG, 50 amps	
Lead (Colors)	All white with tags	
Voltage	250 VAC for 5 A 600 VAC for 10 A, 30 A and 50 A	
Max. Ambient Temp.	-40°C to +80°C	
Contact Material	Precious metal	
Current Rating	5, 10, 30 and 50 amps	
Noise	100 milliohms, max. @ 6 VDC, 50 milliamps, 5 rpm	
Dust / Splash Seals	Standard lip seal	

\*Please note that the operational life of the unit is dependent upon rotational speed, environment and temperature.

Part Number	# of Circuits	Capsule Length (L)	# of Modules
AC6275-6	6 power ckts max. or 36 signal ckts max.	6.6 inch	6
AC6275-12	12 power ckts max. or 72 signal ckts max.	11.2 inch	12
AC6275-18	18 power ckts max. or 108 signal ckts max.	15.7 inch	18
AC6275-24	24 power ckts max. or 144 signal ckts max.	20.5 inch	24

The AC6275 commercial slip ring provides configuration flexibility to meet your application needs. This product can be configured as required, with 5 amp signal, 10 amp rings, 30 amp rings and 50 amp rings.

Four set lengths are available, based on the number of modules that are required. These lengths are provided in the capsule length chart above. Each module has either 1-50 amp ring or 2-30 amp rings. For 10 amp rings, there are 1 to 3 rings per module. For 5 amp rings, there are 6 per module. Blank spacer modules are available for greater separation of power and signal circuits.

- 1) Define the number of signal / 5 amp rings and round up to the closest multiple of 6. Divide by 6 for number of 6 ring modules.
- 2) Define the number of 10 amp rings and round up to the closest multiple of 3 (e.g. 9 divided by 3 equals 3, 3 ring modules).
- 3) Define the number of 30 amp rings and round up to the closest multiple of 2. Divide by 2 for the number of 30 amp modules.
- 4) Total the number of signal / 5, 10 amp, 30 amp and 50 amp modules to define the total number of modules required.
- 5) If your total does not equal the 6, 12, 18 or 24 contained in the 4 lengths above, we will use spacers to fill out the unit to the nearest multiple of 6.

**Example:** 5, 10 amp rings (2 X 3 = 6), 6 / 3 = 2 modules

(3 each) 30 amp rings = 2 modules

+4 modules

⇒ use 6 (closest multiple of 6)

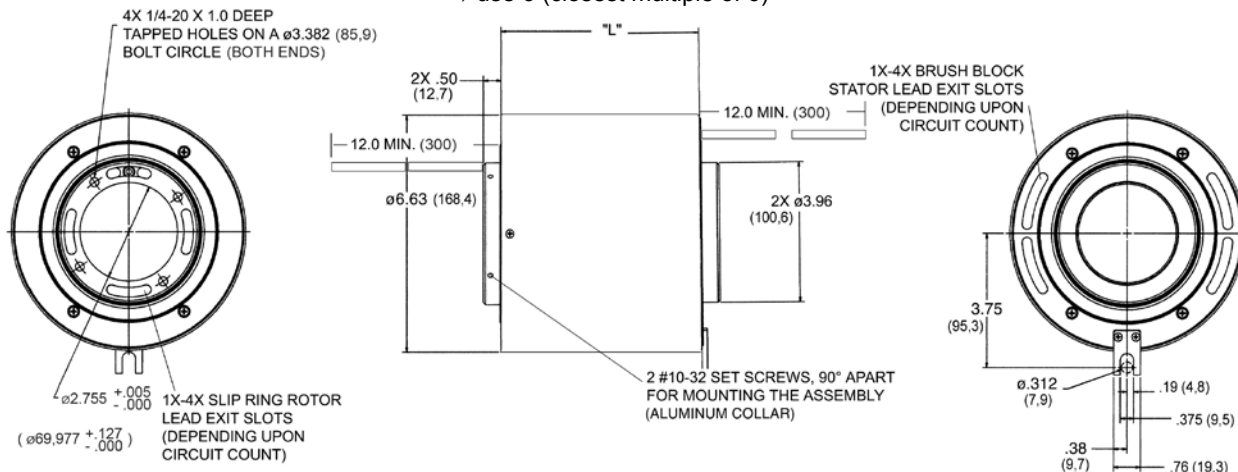

Dimensions in inches (millimeters)

# Slip Rings With Through-Bores

AC6793 Specifications (IP 65 Sealed Version of AC6275)		Options
Operating Speed	1,000 rpm* continuous	<ul style="list-style-type: none"> <li>• Longer lead lengths available</li> <li>• Power and signal combinations</li> <li>• Rotor and stator lead exits</li> <li>• Gold plated rings</li> </ul>
Number of Circuits	Various configurations	
Lead Lengths	12 inch (304 mm) min. from point of exit	
Lead Size	Signal circuits: #20 AWG, 5 amps #16 AWG, 10 amps Power circuits: #10 AWG, 30 amps #8 AWG, 50 amps	
Lead (Colors)	All white with tags	
Voltage	250 VAC for 5A 600 VAC for 10A, 30A and 50A	
Max. Ambient Temp.	-40°C to +80°C	
Contact Material	Precious metal	
Current Rating	5, 10, 30 and 50 amps	
Noise	100 milliohms, max. @ 6 VDC, 50 milliamps, 5 rpm	
Environmental	IP 65 sealed	

\*Please note that the operational life of the unit is dependent upon rotational speed, environment and temperature.

Part Number	# of Circuits	Capsule Length (L)	# of Modules
AC6793-6	6 power ckts max. or 36 signal ckts max.	6.6 inch	6
AC6793-12	12 power ckts max. or 72 signal ckts max.	11.2 inch	12
AC6793-18	18 power ckts max. or 108 signal ckts max.	15.7 inch	18
AC6793-24	24 power ckts max. or 144 signal ckts max.	20.5 inch	24

The AC6275 commercial slip ring provides configuration flexibility to meet your application needs. This product can be configured as required, with 5 amp signal, 10 amp rings, 30 amp rings and 50 amp rings.

Four set lengths are available, based on the number of modules that are required. These lengths are provided in the capsule length chart above. Each module has either 1-50 amp ring or 2-30 amp rings. For 10 amp rings, there are 1 to 3 rings per module. For 5 amp rings, there are 6 per module. Blank spacer modules are available for greater separation of power and signal circuits.

- 1) Define the number of signal / 5 amp rings and round up to the closest multiple of 6. Divide by 6 for number of 6 ring modules.
- 2) Define the number of 10 amp rings and round up to the closest multiple of 3 (e.g. 9 divided by 3 equals 3, 3 ring modules).
- 3) Define the number of 30 amp rings and round up to the closest multiple of 2. Divide by 2 for the number of 30 amp modules.
- 4) Total the number of signal / 5, 10 amp, 30 amp and 50 amp modules to define the total number of modules required.
- 5) If your total does not equal the 6, 12, 18 or 24 contained in the 4 lengths above, we will use spacers to fill out the unit to the nearest multiple of 6.

**Example:** 5, 10 amp rings (2 X 3 = 6), 6 / 3 = 2 modules

(3 each) 30 amp rings = 2 modules

+4 modules

⇒ use 6 (closest multiple of 6)

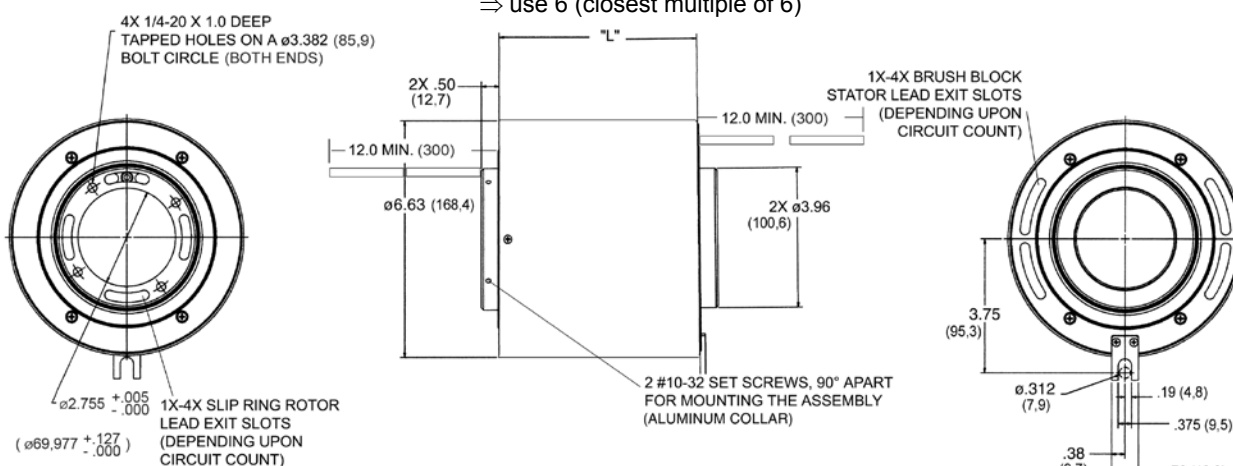

Dimensions in inches (millimeters)

REVISED 05/12