

Slip Rings With Through-Bores

AC6098

4 inch through-bore

Description

A slip ring can be used in any electromechanical system that requires unrestrained, continuous rotation while transferring power and / or data from a stationary to a rotating structure. A slip ring is also called a rotary electrical interface, commutator, collector, swivel or a rotary joint.

The AC6098 is a commercial slip ring capsule that features a 4 inch through-bore and a compact 8.13 inch outside diameter. The through-bore provides routing space for hydraulics, pneumatics, or for a concentric shaft mount.

This slip ring is available in four lengths, from 4.6 to 14.5 inches (depending on the number of circuits required). It can be manufactured with 1 to 72 signal rings or 1 to 24 power rings. This “stacked module” approach allows us to quickly assemble the exact number and type of circuits that our customers require. Unlike most competitive units, the AC6098 transfers low level control and data signals. In addition, signal / data circuits can be combined with power circuits all in the same assembly. The slip ring can run up to 250 rpm continuous.

The AC6098 uses our fiber brush technology which offers several advantages over conventional slip ring contacts including multiple points of contact per brush bundle, low contact force per fiber and low contact wear rates. In addition, fiber brushes do not require lubrication and produce virtually no wear debris.

Features

- 4 inch through-bore
- 1 to 72 signal rings (signal up to 10 amps)
- 1 to 24 power rings (30 amp or 50 amp or some combination)
- Can combine signal and power in same slip ring
- Handles controller signals
- Speeds up to 250 rpm
- Silver plated rings; silver alloy fiber brushes
- Sealed against dust and splash
- Brush assemblies are field serviceable (if required)

Benefits

- Compact design
- Design flexibility to meet your requirements
- Transfers low level control and data signals
- Provides the exact number of circuits required
- Fiber brush technology provides maintenance-free operation (no cleaning or lubrication required)

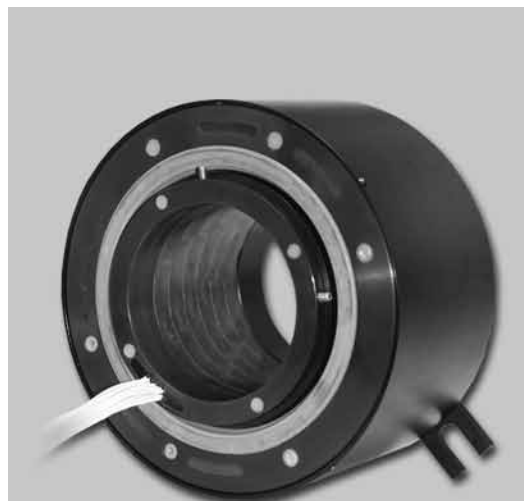

Typical Applications

- Industrial machinery - machining centers, rotary index tables, heavy equipment turrets or cable reels, test equipment, packaging and palletizing machines, robotics, process equipment and rotary sensors
- Amusement rides
- Exhibit / display equipment
- Medical equipment

Slip Rings With Through-Bores

AC6098 Specifications		Options
Operating Speed	250 rpm*	<ul style="list-style-type: none"> Longer lead lengths available Power and signal combinations Gold plated rings Seamed housing standard, solid housing optional
Number of Circuits	Various configurations	
Lead Lengths	12 inch (304 mm) min. from point of exit	
Lead Size	Signal circuits: #16 AWG, 10 amps Power circuits: #10 AWG, 30 amps #8 AWG, 50 amps	
Leads	All white with tags	
Voltage	600 VAC	
Max. Ambient Temp.	80°C	
Contact Material	Precious metal	
Current Rating	10, 30 and 50 amps	
Noise	100 milliohms, max. @ 6 VDC, 50 milliamps, 5 rpm	
Dust / Splash Seals	Standard lip seal	

*Please note that the operational life of the unit is dependent upon rotational speed, environment and temperature.

Part Number	# of Circuits	Capsule Length	# of Modules
AC6098-6	6 power ckts max. or 18 signal ckts max.	4.43 inch (112,5 millimeters)	1 to 6
AC6098-12	12 power ckts max. or 36 signal ckts max.	7.78 inch (197,5)	7 to 12
AC6098-18	18 power ckts max. or 54 signal ckts max.	11.12 inch (282,6)	13 to 18
AC6098-24	24 power ckts max. or 72 signal ckts max.	14.47 inch (368,3)	19 to 24

The AC6098 commercial slip ring provides configuration flexibility to meet your application needs. This product can be configured as required, with signal / 10 amp rings, 30 amp rings and 50 amp rings.

Four set lengths are available, based on the number of modules that are required. These lengths are provided in the capsule length chart above. Blank spacer modules are available for greater separation of power and signal circuits. Each 30 amp and 50 amp ring is one module. For signal / 10 amp rings, there are 1 to 3 rings per module. To determine the length of your capsule:

- 1) Define the number of signal / 10 amp rings, and round up to the closest multiple of 3 (i.e. 7 signal rings rounds up to 9 rings).
- 2) Divide this number by 3 to determine the number of signal / 10 amp modules.
- 3) Total the number of signal / 10 amp, 30 amp and 50 amp modules to define the total number of modules required.
- 4) If your total does not equal the 6, 12 18 or 24 contained in the 4 lengths above, we will use spacers to fill out the unit to the nearest multiple of 6.

Example: 5 signal rings (2 X 3 = 6), 6 / 3 = 2 signal modules

(3 each) 30 amp rings = 3 modules

+5 modules

⇒ use 6 (closest multiple of 6)

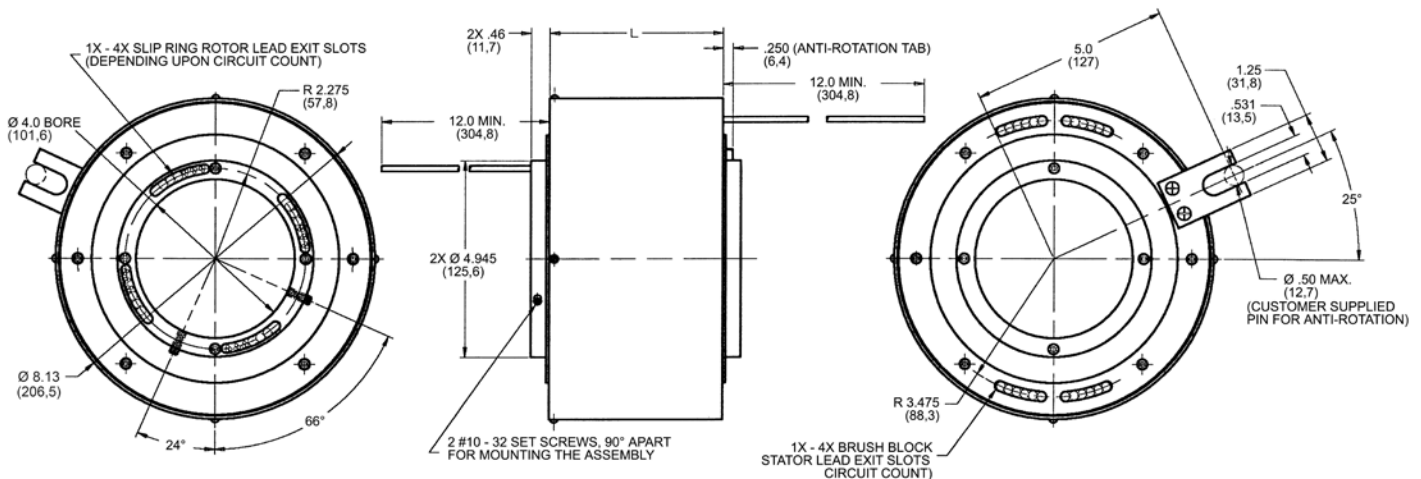

Dimensions in inches (millimeters)