

High Speed Slip Ring Capsules

AC3757

Miniature slip ring assembly

Description

A slip ring can be used in any electromechanical system that requires unrestrained, continuous rotation while transferring power and / or data from a stationary to a rotating structure. A slip ring is also called a rotary electrical interface, commutator, collector, swivel or a rotary joint.

The AC3757 high speed slip ring provides 36 circuits and operational speeds up to 6,000 rpm. Our fiber brush technology minimizes contact wear and resultant debris while it extends operational life.

Features

- 36 circuits
- High speed performance with customer's cooling systems:
 - 4,000 rpm without cooling
 - 6,000 rpm with gas cooling (nitrogen)
- Thermocoupled leads are available
- Low noise. The low contact force of the fiber brush design reduces resistance (noise) while providing superior power and data transfer capability.
- Cooling tubes

Benefits

- Fiber brush technology. The sliding electrical contacts used in the AC3757 slip ring features our fiber brush technology to provide these benefits:
 - Low contact force per fiber
 - Low contact wear rates
 - Contact surfaces that do not require lubrication
 - Ability to perform in vacuum and varied ambient conditions
- Improved system performance. Slip rings can improve mechanical performance, simplify system operation and eliminate damage-prone wires dangling from movable joints.



Typical Applications

This slip ring provides high speed performance and is successfully serving in applications such as:

- Centrifuges
- Tire testing
- Gasoline or diesel engine testing

High Speed Slip Ring Capsules

AC3757 Specifications	
Ring O.D.	0.270 inch
Ring Pitch	0.032 inch
Flange Diameter	1.600 inch
Bore	None
Volts (Peak to Peak)	70
Circuits	Leads
1-26	30 (19 / 42) AWG silver plated standard copper conductor
27-36	Solid chromel & alumel leads
All leads are color coded extruded teflon insulation.	
Chromel / alumel thermocouple pairs are attached to each bearing and to brushes #1 and #12 to monitor temperature.	

Lead Wire Color Codes							
Ring #	Color Code	Ring #	Color Code	Ring #	Color Code	Ring #	Color Code
1	BLK	10	WHT	19	WHT-GRY	28	ORN (ALUMEL)
2	BRN	11	WHT-BLK	20	WHT-BLK-BRN	29	BLK (CHROMEL)
3	RED	12	WHT-BRN	21	WHT-BLK-RED	30	BRN (ALUMEL)
4	ORN	13	WHT-RED	22	WHT-BLK-ORN	31	RED (CHROMEL)
5	YEL	14	WHT-ORN	23	WHT-BLK-YEL	32	ORN (ALUMEL)
6	GRN	15	WHT-YEL	24	WHT-BLK-GRN	33	BLK (CHROMEL)
7	BLU	16	WHT-GRN	25	WHT-BLK-BLU	34	BRN (ALUMEL)
8	VIO	17	WHT-BLU	26	WHT-BLK-VIO	35	RED (CHROMEL)
9	GRY	18	WHT-VIO	27	RED (CHROMEL)	36	ORN (ALUMEL)

Note: Other combinations of standard conductors and thermocouple leads are available.

Recommended Mounting Arrangement

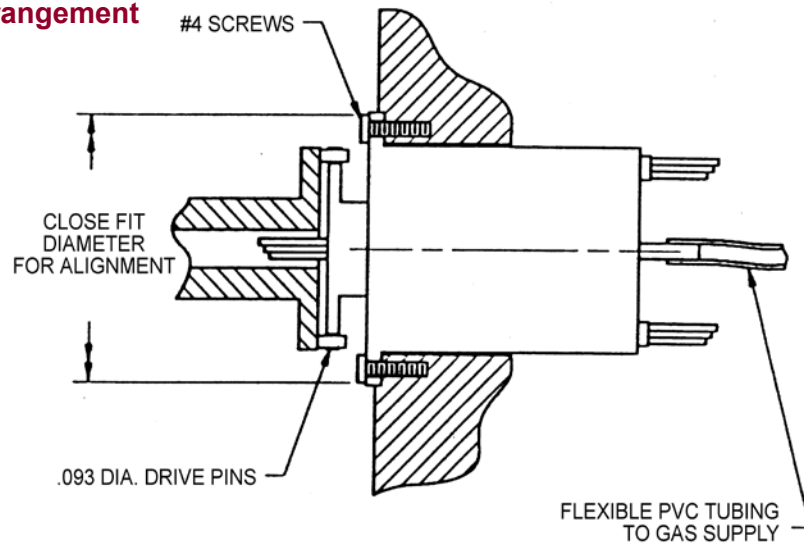

AC3757 Dimensions

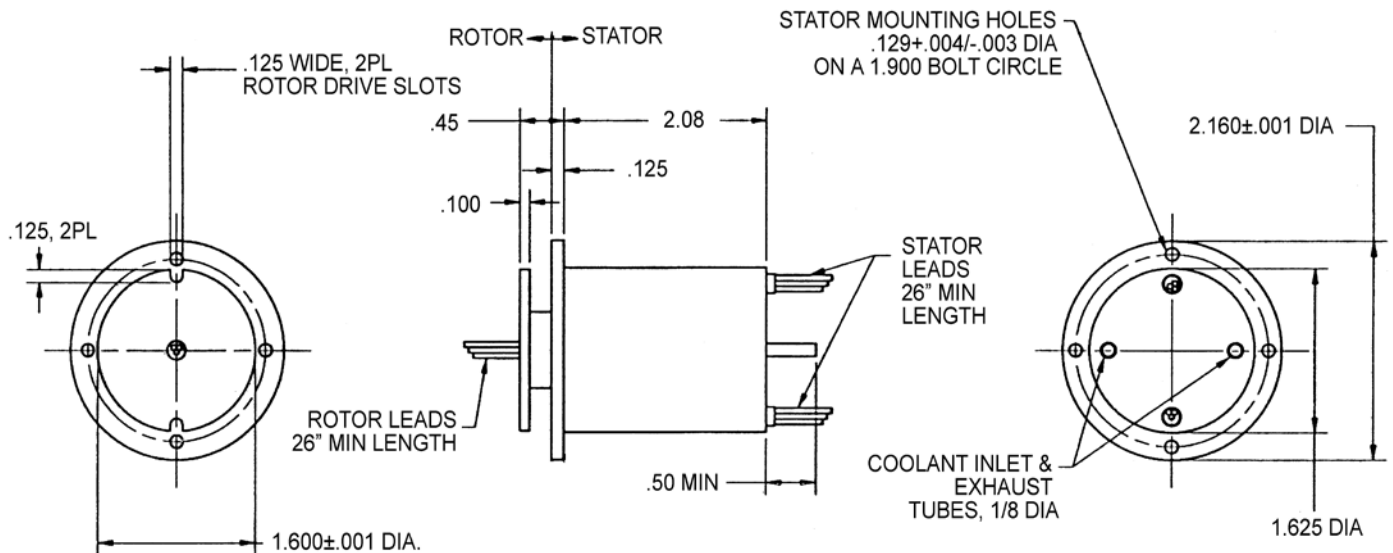

Dimensions in inches